

Instruction for disassembly

ECblue-external rotor motors of motor size
B (090), D (116) and G (152)



1 General notes

Instruction for disassembly and ecologically meaningful disposal of motor components of ECblue-external rotor motors according to regulation (EU) No. 1253/2014. Valid for motor size "B" (090), "D" (116) and "G" (152).

The used motor size is recognisable from the type designation (☞ rating plate).

Examples for type designations with motor size B = 90		
Motors Type	Axial fans type	Centrifugal fans type
MK090 - _ _ . _ _ . _ _	F _ _ _ _ - _ . B _ _ _ _	RH _ _ _ - _ . B _ _ _ _ GR _ _ _ - _ . B _ _ _ _ ER _ _ _ - _ . B _ _ _ _

2 Safety instructions



Attention!

- Observe the assembly instructions of the product! Ensure in particular compliance with all safety specifications!
- The high magnetic forces of attraction between the rotor and the stator present a risk of injury.

3 Disassemble fan



Danger due to electric current

- The 5 electrical safety rules must be observed!
- When the motor runs independently due to air flowing through or if it continues to run down after being turned off, dangerous voltages of over 50 V can arise on the motor internal connections through operation of the generator.
- Through use of capacitors, danger of death exists even after switching off the device through directly touching the energized parts or due to parts that have become energized due to faults.
- The controller housing may only be removed or opened when the power line has been switched off and a period of three minutes has elapsed since switching it off.

Procedure

1. Turn off the line voltage and secure against switching back on.
2. Clean any external contaminations from the fan prior to disassembly.
3. Depending on the fan's construction, remove the external components like the wall ring (2) and the protective grille (1), and check that these can be reused.

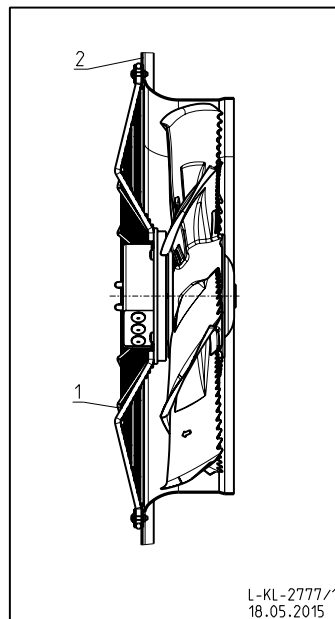

4. Wait for at least 3 minutes before removing the cover from the controller housing.
5. Check safe isolation from supply.
6. Disconnect all electrical cables.

4 Tools for disassembly

The following tools are required for disassembly:

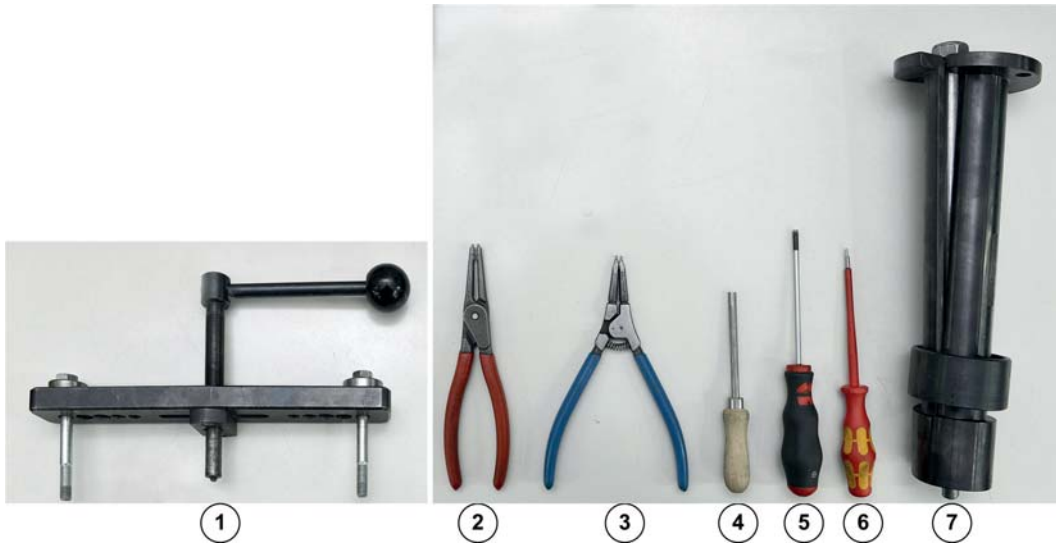

- 1 Bar extractor
- 2 Pliers for outer circlip
- 3 Pliers for inner circlip
- 4 Release toll for motor size D (116) and G (152)
- 5 For Motor size B (090) screwdriver TX20 (TR TX20 for security torx), for motor size D (116) and G (152) screwdriver TX25
- 6 Slotted screwdriver (e.g. 0.6) for motor size D (116) and G (152)
- 7 Withdrawal sleeve incl. round material for extracting the ball bearing on the stator side

Special tool available from ZIEHL-ABEGG

Motor size	Release tool		Bar extractor		Extractor sleeve	
	Drawing number	Part numbers	Drawing number	Part numbers	Drawing number	Part numbers
B (090)	-	-	6003-201	00280698	6003-212	00703644
D (116)	6003-019	00161068	6003-202	00280682	6003-209	00295437
G (152)	6003-019	00161068	6003-202	00280682	6003-211	00296476

5 Procedure for disassembly

5.1 Opening the motor

Remove the cover from the controller housing

- ▷ For motor size B (090)
 - 2 x Torx of connection area cover solve with screwdriver “5” TX20.
 - 4 x Security Torx TR of controller cover solve with screwdriver “5” TX20.
- ▷ For motor size D (116) solve 5 screws (combi Torx T20) with screwdriver “5”.
- ▷ For motor size G (152) solve 6 screws (combi Torx T20) with screwdriver “5”.

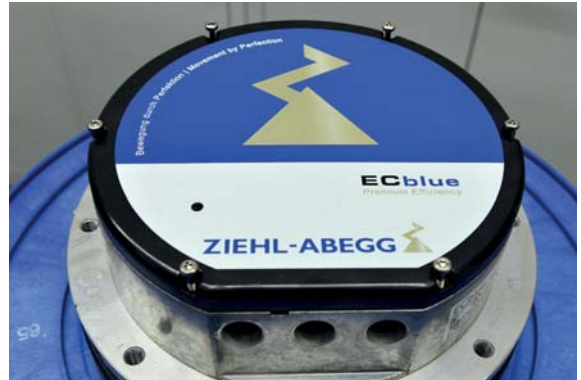
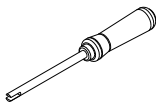

Illustration motor size G (152)

Motor size D (116) and G (152)

- ▷ Remove any add-on module present from its slot.
- ▷ Loosen the locking bolts using the release tool “4”.



Information

- Earlier versions are designed with a Torx T10 plastic screw, which must be loosened here.

- ▷ Push the retaining clips using the screwdriver “6” and remove the black inner cover.



5.2 Disassemble the motor and remove ball bearings

- ▷ Remove the inner circlip using pliers “3” and dispose of it.

Attention!

- Do not reuse the circlip due to the risk of overstretching.



- ▷ Remove and dispose of the plastic washer.

Information

- The plastic washer is not present in the version with hybrid bearings and steel shaft without plastic encapsulation.

Attention!

- Do not reuse the plastic washer.



- ▷ Remove the outer circlip using pliers “2” and dispose of it.

Attention!

- Do not reuse the circlip due to the risk of overstretching.



- ▷ Place the extraction tool “1” on the stator and secure to the stator flange.

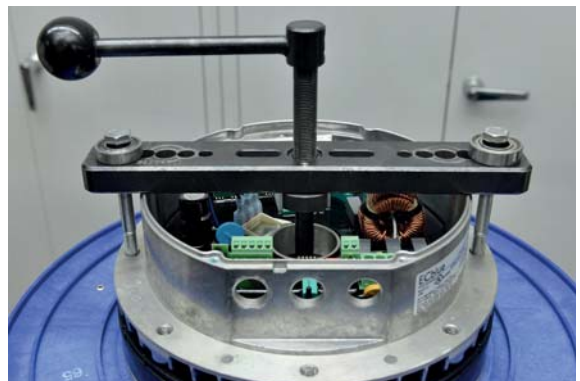

- ▷ Remove the stator "A" from the rotor using the extraction tool "1" by pressing the threaded spindle onto the front face "Z".
- ▷ Remove the stator "A" from the magnetic field of the rotor using "B" using the extraction tool.
- ▷ Remove the extraction tool from the stator.

Attention!

- Never attempt to remove the stator and rotor manually without an extraction tool.
- There is a strong attraction between the stator "A" and the rotor "B" because of high magnetic forces – danger of injury!

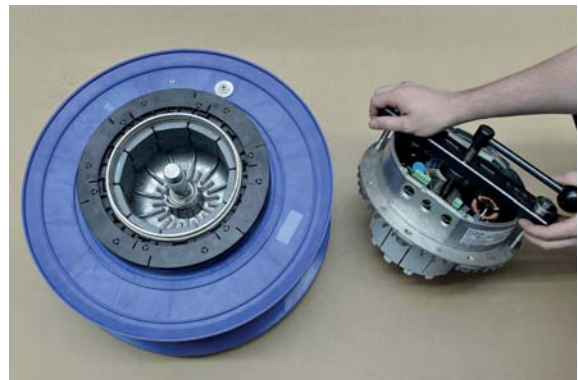
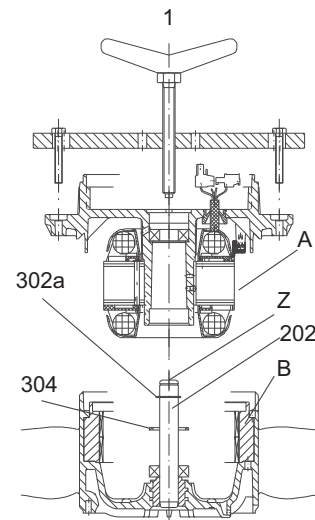

- ▷ Remove and dispose of the plastic washer.

Information

- The plastic washer is not present in the version with hybrid bearings and steel shaft without plastic encapsulation.

Attention!

- Do not reuse the plastic washer.



- ▷ Remove the lower circlip "302a" using pliers "3" and dispose of it.

Information

- Newer versions have neither plastic washers nor circlips.

Attention!

- Do not reuse the circlip due to the risk of overstretching.



- ▷ Remove the ball bearing on the stator side using suitable round material.



- ▷ Remove the ball bearing on the rotor side using the extraction sleeve "7".

If no suitable press is available, the ball bearing can be pushed off using the extraction tool and a shaft.



- ▷ Remove the plastic washer from the shaft and dispose of it.

Information

- Only in version with aluminium die-cast motor.
- For version with steel rotor remove plastic cooling wheel from the ground of the rotor and dispose of it.

- ▷ Remove plastic cooling rings from rotor flange with an appropriate lifting tool (e.g. screwdriver "6" and dispose of it.

Information

- For motor size G with steel rotor instead loosen screw M5 with screwdriver "5" TX25 and remove cooling ring.



Aluminium die-cast rotor with plastic washer (not shown) on flange



Steel rotor with plastic cooling fan



Attention!

Removed components must not be reused!

6 Disposal / recycling



Disposal must be carried out professionally and in an environmentally friendly way in accordance with the respective national legal stipulations.

- ▷ Separate the materials by type and in an environmentally friendly way.
- ▷ If necessary, commission a specialist company with the waste disposal.

7 Enclosure

7.1 Manufacturer

Our products are manufactured in compliance with valid international standards and regulations. If you have any questions about how to use our products or if you are planning special applications, please contact:

ZIEHL-ABEGG SE
Heinz-Ziehl-Straße
D-74653 Künzelsau
Phone 07940/16-0
Fax 07940/16-300
info@ziehl-abegg.de

7.2 Service address

Please refer to the homepage at www.ziehl-abegg.com for a list of our subsidiaries worldwide.